



# Explanation in the Era of LLMs

NAACL 2024 tutorial  
Section 4: Transformer Understanding

Presented by Sarah Wiegrefe  
Thanks Xi and Chenhao for help with slides.

# Tutorial @ EACL 2024: Transformer-Specific Interpretability

[Website](#)

[Slides](#)

[Recording](#)

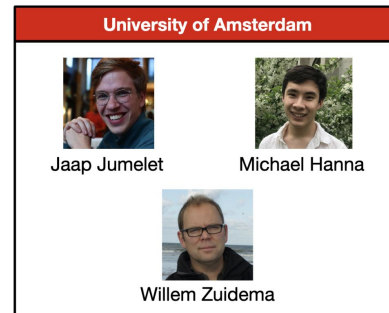
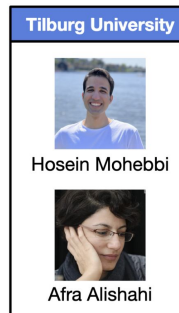

# Tutorial @ NAACL 2021: Fine-grained Interpretation and Causation Analysis in Deep NLP Models

[Website/Slides](#)

[Recording](#)

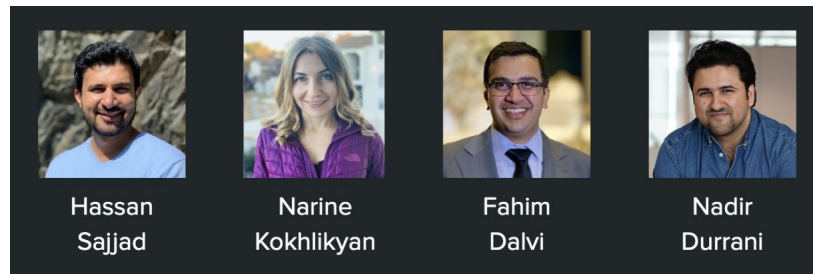

# Tutorial @ EMNLP 2022: Causal Inference for NLP

[Slides/Slides](#)

[Recording](#)

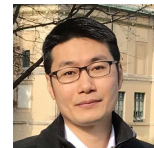

# Mechanistic Interpretability Workshop @ ICML 2024

[Website](#)



**Fazl Barez**  
Research Fellow University  
of Oxford



**Mor Geva**  
Ass. Prof Tel Aviv  
University, Visiting  
Researcher Google  
Research



**Lawrence Chan**  
PhD student UC Berkeley



**Kayo Yin**  
PhD student UC Berkeley



**Neel Nanda**  
Research Engineer Google  
DeepMind



**Max Tegmark**  
Professor MIT

# Survey Papers

[A Primer on the Inner Workings of Transformer Language Models](#)

[Toward Transparent AI: A Survey on Interpreting the Inner Structures of Deep Neural Networks](#)

# Outline



1. Neuron-level interpretability
  - a. Sparse Autoencoders
2. Causal Mediation
  - a. Activation Patching & variants
  - b. Causal abstraction & other methods
3. What is mechanistic interpretability?
4. Methods Leveraging Language Model Strengths
  - a. Transformer Residual Stream and Linear Structure
  - b. Vocabulary projection
  - c. Decoding Natural Language Explanations from Representations
5. Conclusion + Q&A

---

# Neuron-Level Interpretability

## Background

# Interpreting Neurons

- Neuron = a single dimension of a hidden state representation
- Line of work traditionally does not consider structure

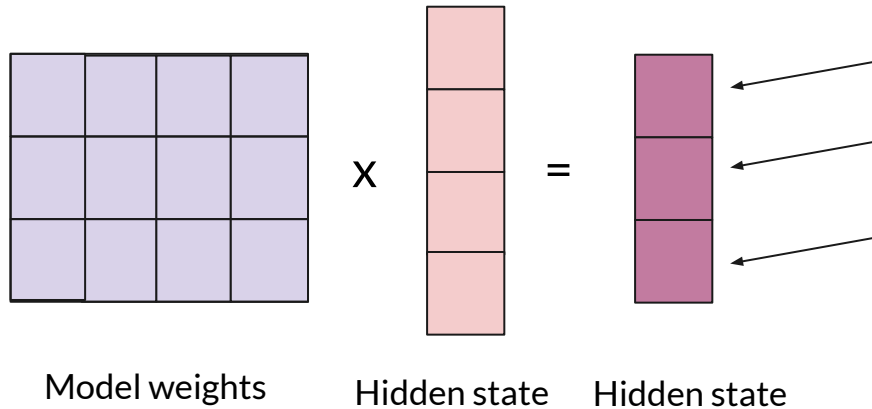

What pattern in the inputs will fire a neuron (i.e., cause high values at a particular dimension)?

# Interpreting Neurons of NLP Models

## Activations of neurons for certain properties

Supports the efforts of the Libyan authorities to recover funds misappropriated under the Qadhafi regime

(a) English Verb (#1902)

einige von Ihnen haben vielleicht davon gehört , dass ich vor ein paar Wochen eine Anzeige bei Ebay geschaltet habe .

(b) German Article (#590)

Layer14, Unit 224: sure, know, aware

- Are you sure you are aware of our full potential?
- They know that and we know that.
- I am sure you will understand.
- I am sure you will do this.
- I am confident that we will find a solution.

# Pitfalls of Neuron-Level Analysis in NLP



- Methods generally ignore interactions between neurons.
- There are a LOT of neurons in modern models.



# Pitfalls of Visualization/Looking at Examples



- Humans are biased towards simple and clear concepts.

- *"What is the meaning behind the song "Angel" by Eric Clapton?"*
- *"What's the meaning of Johnny Cash's song "King of the Hill"?"*
- *"What is the meaning behind the Tears for Fears song "Mad World", such as the lyric, "All around me are familiar faces"?"*

Song titles? Syntactic sentence structure?

# Pitfalls of Visualization/Looking at Examples

- Humans are biased towards simple and clear concepts.

- *"What is the meaning behind the song "Angel" by Eric Clapton?"*
- *"What's the meaning of Johnny Cash's song "King of the Hill"?"*
- *"What is the meaning behind the Tears for Fears song "Mad World", such as the lyric, "All around me are familiar faces"?"*

Song titles? Syntactic sentence structure?

- *On 16 June 2006, it was announced that Everton had entered into talks with Knowsley Council and Tesco over the possibility of building a new 55,000 seat stadium, ex-pandable to over 60,000, in Kirkby.*
- *On 15 September 1940, known as the Battle of Britain Day, an RAF pilot, Ray Holmes of No. 504 Squadron RAF rammed a German bomber he believed was going to bomb the Palace.*
- *On 20 August 2010, Queen's manager Jim Beach put out a Newsletter stating that the band had signed a new contract with Universal Music.*

Historical events? Sentences with dates at the beginning?

- **Polysemanticity:** neurons "respond to multiple unrelated inputs"

---

# Neuron-Level Interpretability

## Sparse Autoencoders

# Linear Combinations of Neurons as Concepts



Individual neuron-level interpretations are typically not precise:  
many neurons respond to mixtures of concepts

# Linear Combinations of Neurons as Concepts

Individual neuron-level interpretations are typically not precise:  
many neurons respond to mixtures of concepts

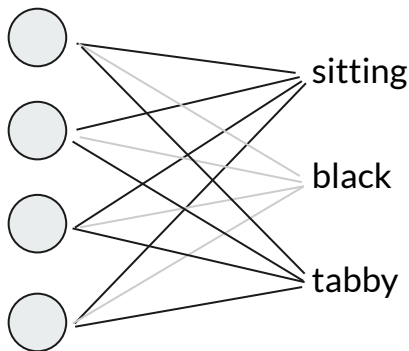

## Hypothesis

Neurons together (as opposed to individual neurons)  
respond to concepts

Neuron activations can be decomposed into linear  
combinations of concept directions (called features)

# Decomposing Activations

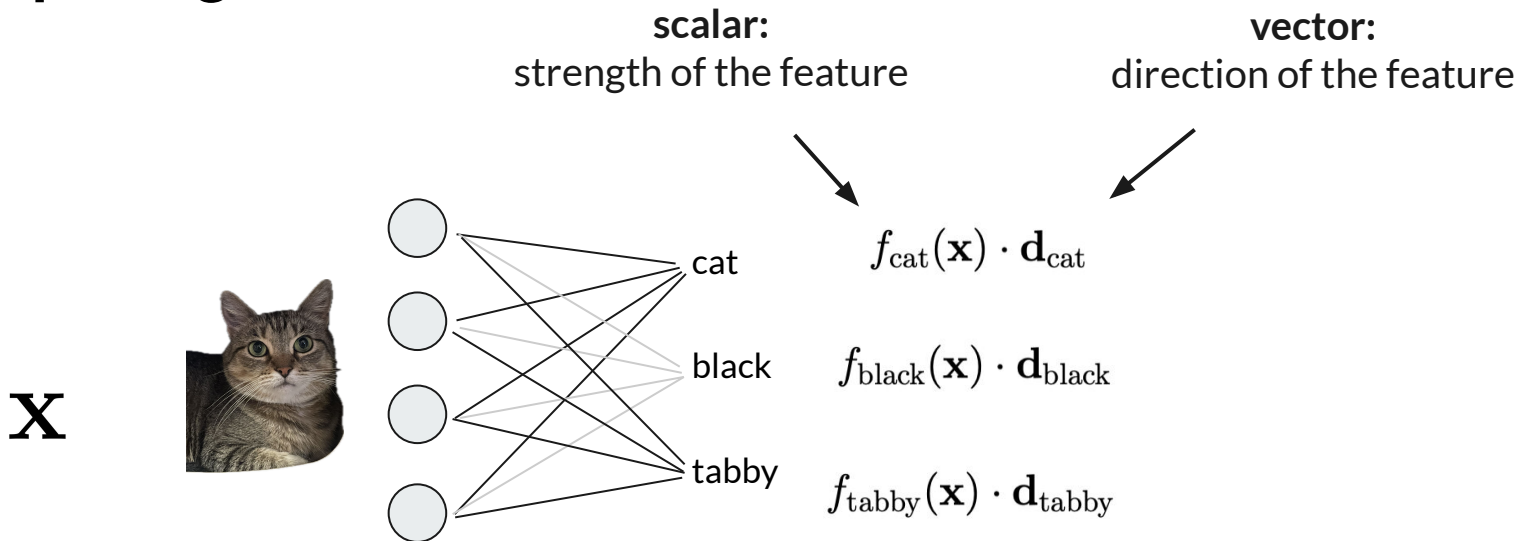

$$\mathbf{X} \xrightarrow{\text{decompose}} f_{\text{cat}}(\mathbf{x}) \cdot \mathbf{d}_{\text{cat}} + f_{\text{black}}(\mathbf{x}) \cdot \mathbf{d}_{\text{black}} + f_{\text{tabby}}(\mathbf{x}) \cdot \mathbf{d}_{\text{tabby}}$$

# Decomposing Activations with Sparse Autoencoders

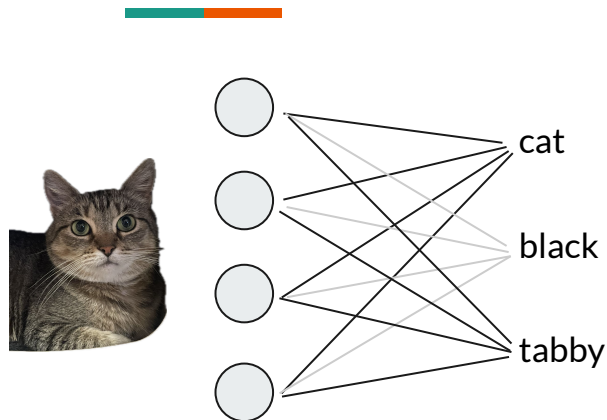

**Sparsity:** for  $\mathbf{X}$ , we expect only a small number of feature  $c$  is activated ( $f_c(\mathbf{x}) > 0$ )

$$\mathbf{x} \approx \mathbf{b} + \sum_c f_c(\mathbf{x}) \mathbf{d}_c$$

using **Sparse Autoencoders** to find decompositions

$f_c(\mathbf{x})$  : encoder parameters       $\mathbf{d}_c$  : decoder parameters

# Decomposing Activations with Sparse Autoencoders

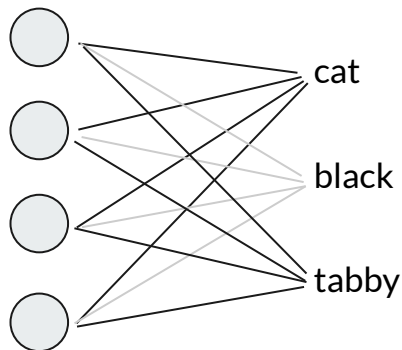

**Sparsity:** for  $\mathbf{X}$ , we expect only a small number of feature  $c$  is activated ( $f_c(\mathbf{x}) > 0$ )

$$\mathbf{x} \approx \mathbf{b} + \sum_c f_c(\mathbf{x}) \mathbf{d}_c$$

using **Sparse Autoencoders** to find decompositions

$f_c(\mathbf{x})$ : encoder parameters       $\mathbf{d}_c$ : decoder parameters

reconstruction loss

sparsity

Loss:  $\mathbb{E}_x \left[ \left\| x - \hat{x} \right\|_2^2 + \lambda \sum_c f_c(x) \right]$



# Notes on Learned Features

## Example: 1M/3 Transit infrastructure

cross one particular bridge, which is a massive  
en route. Since the underwater tunnel between  
) on the approaches to bridges/tunnels and in  
continue north across the aqueduct toward Wrexham  
the case for the Transbay Tube which requires

Intervening on feature activations has an influence on behavior

Default output gives reasonable navigation directions

```
Human: What's the best way to get to the grocery store down the street? Be brief.
```

```
Assistant: 1. Walk.
```

with **Transit infrastructure** clamped to 5x its max

F#1M/3

It confabulates a bridge

```
Human: What's the best way to get to the grocery store down the street? Be brief.
```

```
Assistant: 1. Walk across the bridge.
```

[[Anthropic, 2024](#)]

[[Anthropic, 2023](#)]

# Notes on Learned Features

## Example: 1M/3 Transit infrastructure

cross one particular bridge, which is a massi  
en route. Since the underwater tunnel between  
) on the approaches to bridges/tunnels and in  
ntinue north across the aqueduct toward Wrexha  
the case for the Transbay Tube which requires

Intervening on feature activations has an influence on behavior

Feature activations are more specific than neurons

- “upon manual inspection of a random sample of 50 neurons and features each, the neurons appear significantly less interpretable than the features, typically activating in multiple unrelated contexts..”

[\[Anthropic, 2024\]](#)

[\[Anthropic, 2023\]](#)

---

# Causal Mediation in Transformers

## Activation Patching & variants

# Causal Mediation

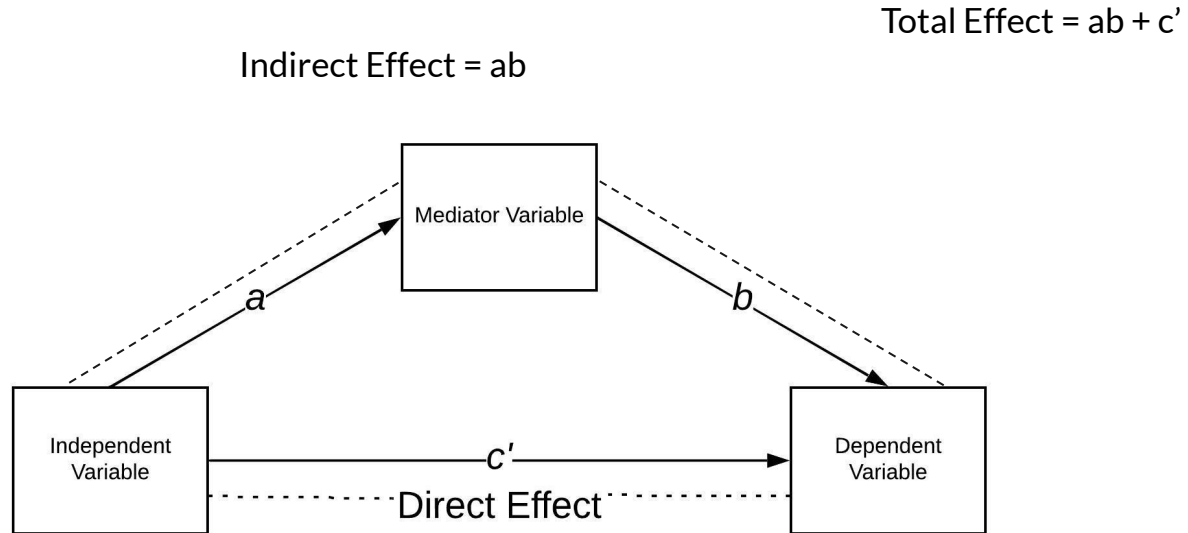

# Activation Patching/Causal Tracing

- Run inference through the network twice
- Measure the change in probabilities of the tokens of interest

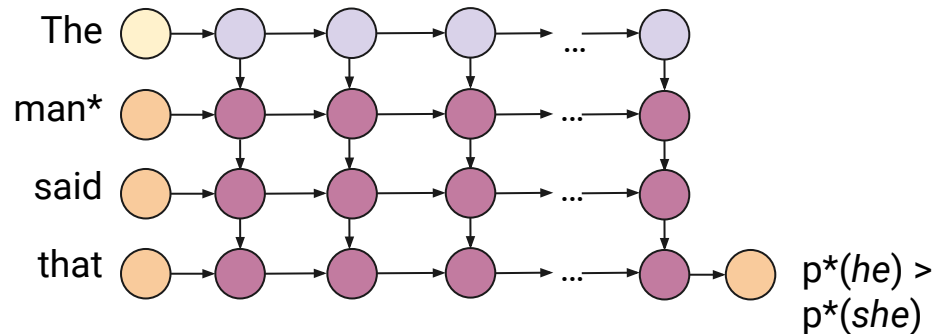
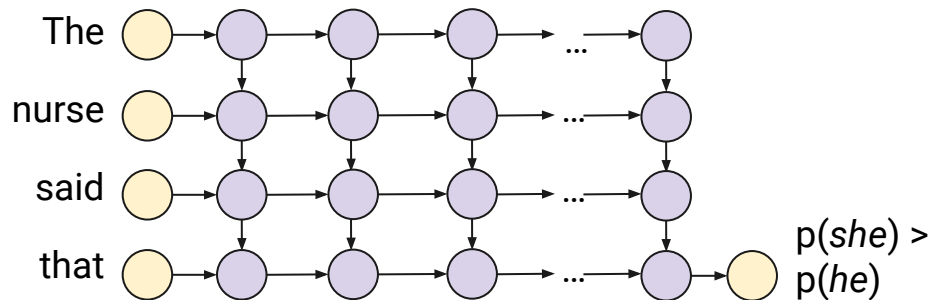

# Activation Patching/Causal Tracing

- Run inference through the network twice
- Measure the change in probabilities of the tokens of interest
- *Patch* in states from one inference run into another
- Observe how probabilities change → the most important hidden states will have the largest effect in “restoring” the probabilities of the run that is being patched in.

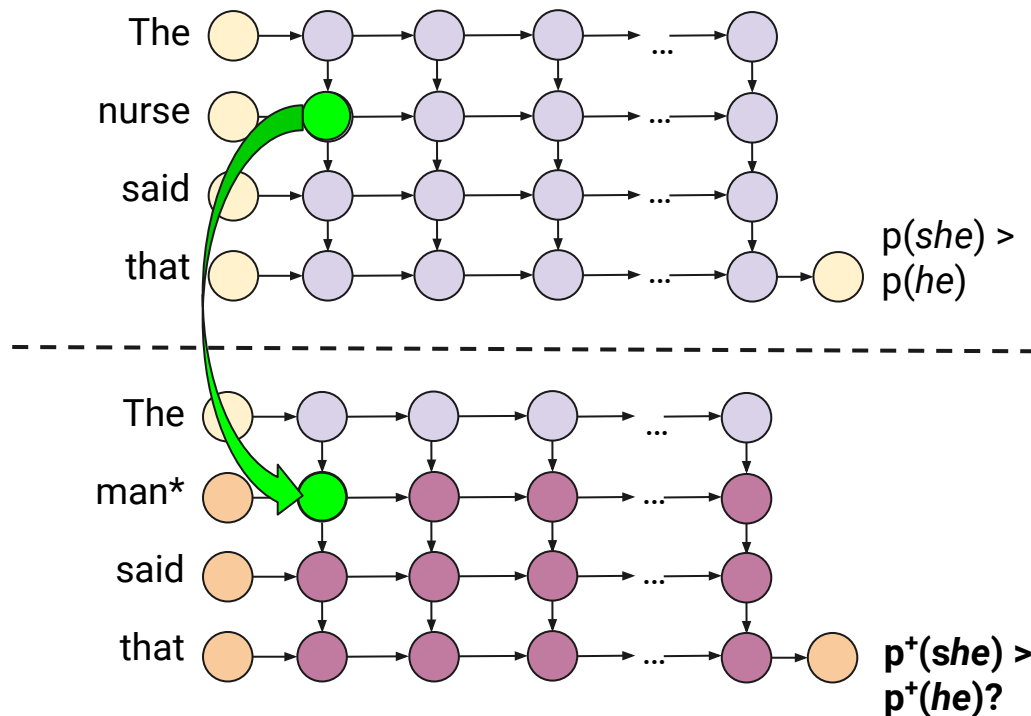

# Activation Patching/Causal Tracing

- Run inference through the network twice
- Measure the change in probabilities of the tokens of interest
- *Patch* in states from one inference run into another
- Observe how probabilities change → the most important hidden states will have the largest effect in “restoring” the probabilities of the run that is being patched in.

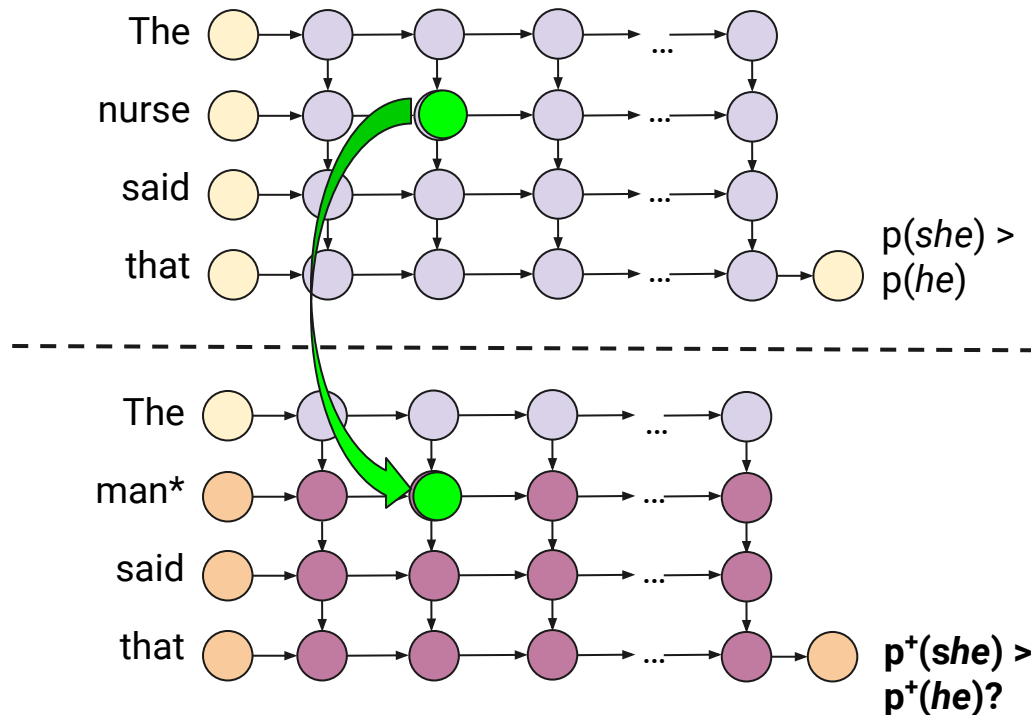

# Method

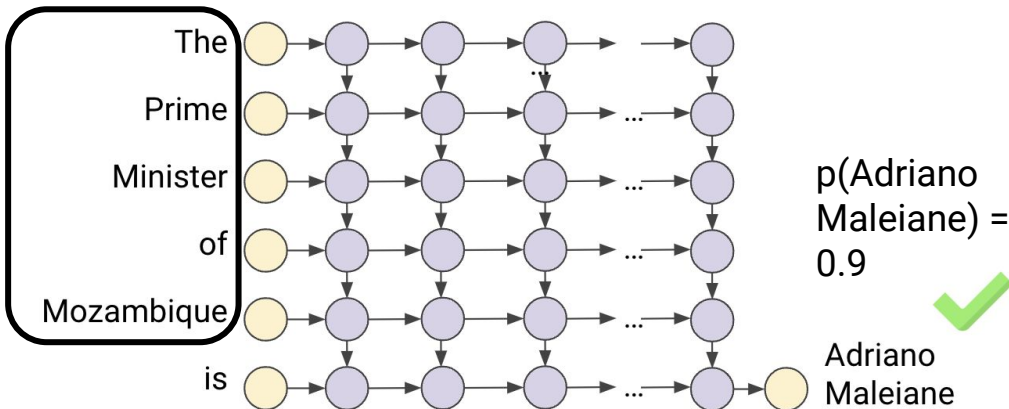

Textual Effect =  
 $p(y) - p^*(y) = 0.89$

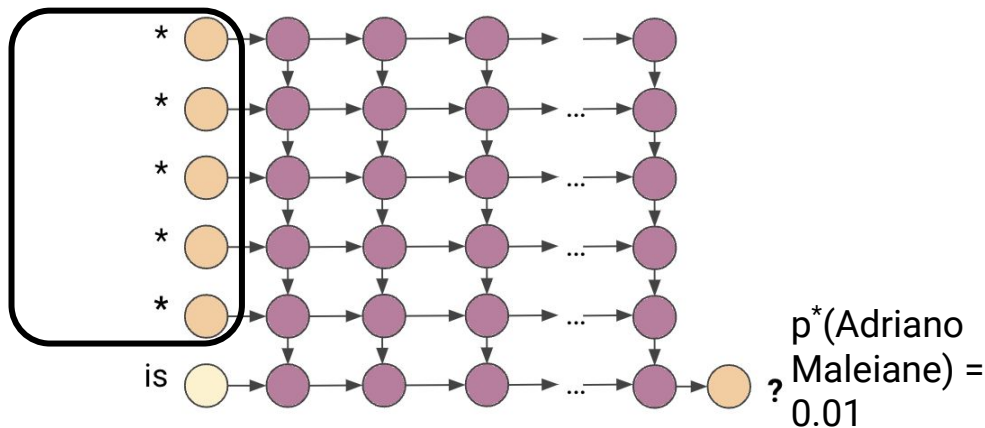



# Method



**Textual Effect =**  
 $p(y) - p^*(y) = 0.89$

**Effect of Repair =**  
 $p^+(y) - p^*(y) = 0.19$

**Fractional Effect of Repair =**  
 $[p^+(y) - p^*(y)] / [p(y) - p^*(y)] = 21.34\%$

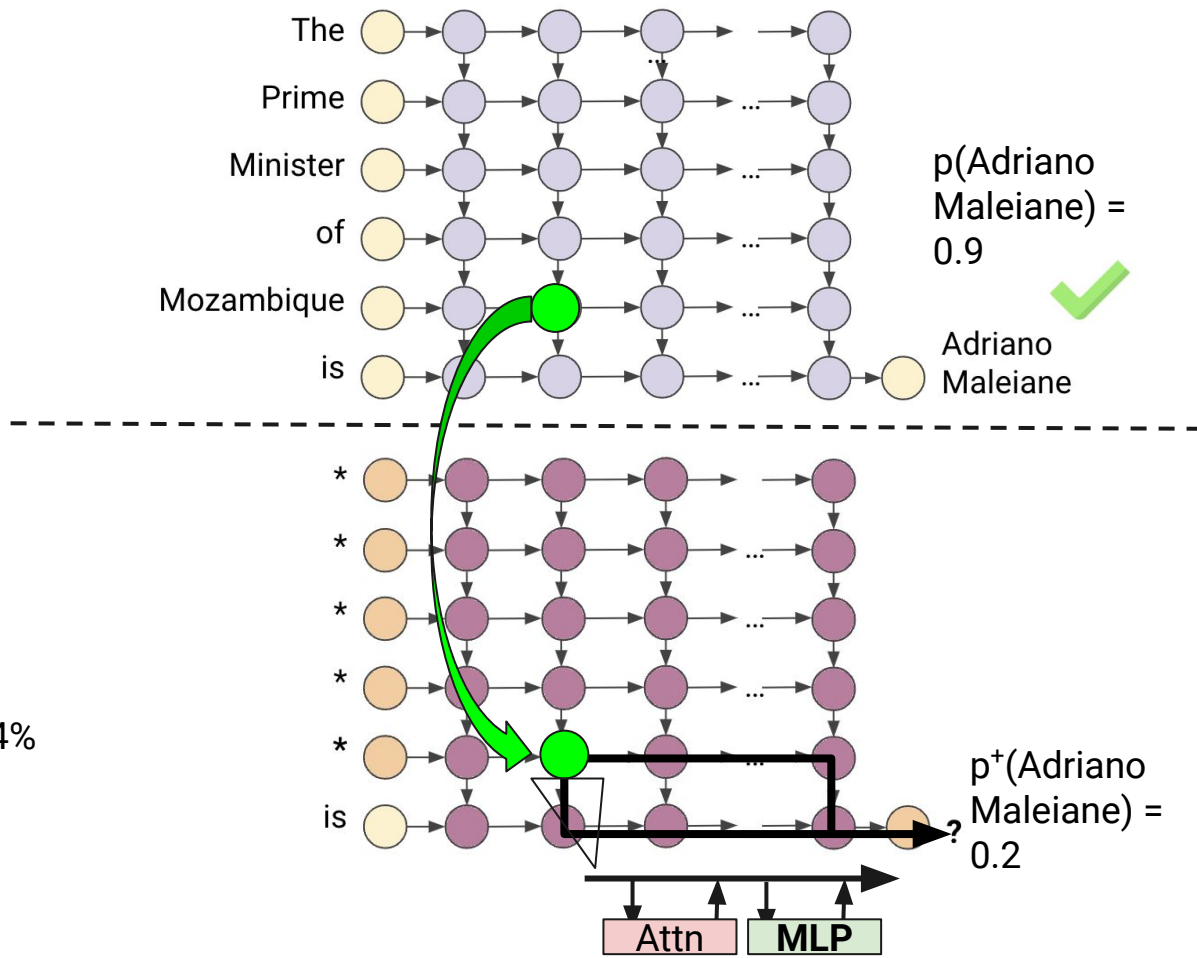

# Results



(e) Impact of restoring state after corrupted input

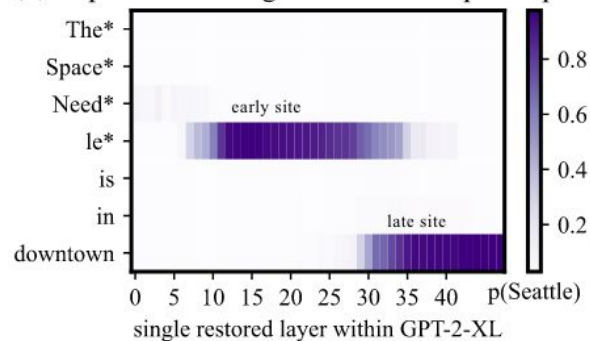

(f) Impact of restoring MLP after corrupted input

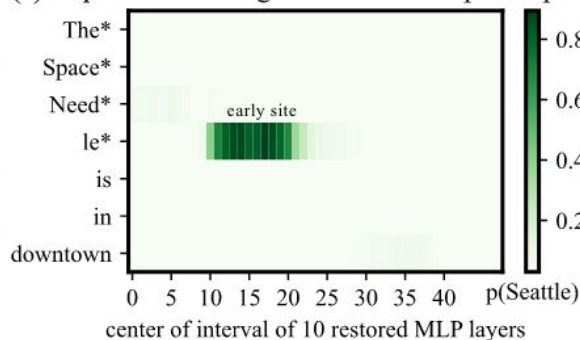

(g) Impact of restoring Attn after corrupted input

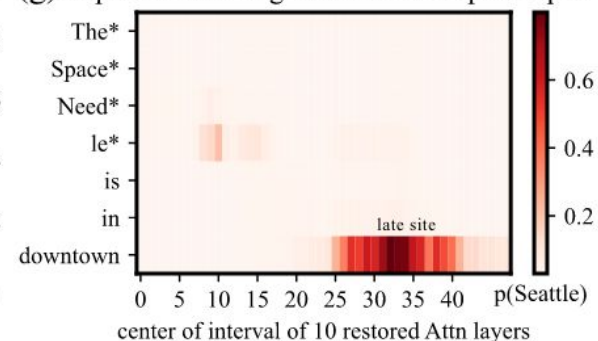

# Notes

- Measures **total effect** of hidden state on output
- Method is rather **computationally expensive**
  - Each patch is a separate inference run
  - Also requires two copies of the model to be loaded into memory, generally
- **Strong independence assumption** about individual hidden states or neurons in the network
  - Ideally, one could patch multiple states at once, but enumerating all possible combinations of states is intractable
- More efficient (gradient-based) approximation: “Attribution Patching” [Nanda 2022, Kramár et al. 2024]
- How to design paired instances? [Zhang & Nanda 2024]

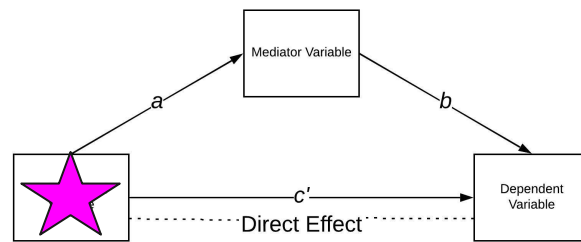

# Path Patching

- Controls more carefully **which effect** you can measure

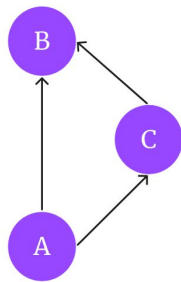

(a) Clean forward pass, no intervention

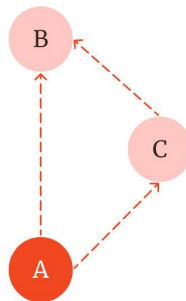

(b) Intervene on A to observe *total* effect on B.

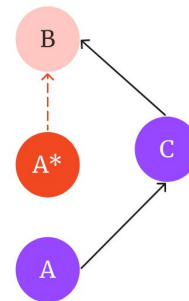

(c) Intervene on the edge A→B to observe *direct* effect on B.

[[Goldowsky-Dill et al. 2023](#)]

Slide credit: [Lieberum et al. 2023](#)

---

# Causal Mediation in Transformers

Causal Abstraction & other methods

# Causal Abstraction

The key idea is to learn a causal graph that maps to the neural network.

Consider the simple task of determining whether  $Z$  is in the interval  $[X, Y]$

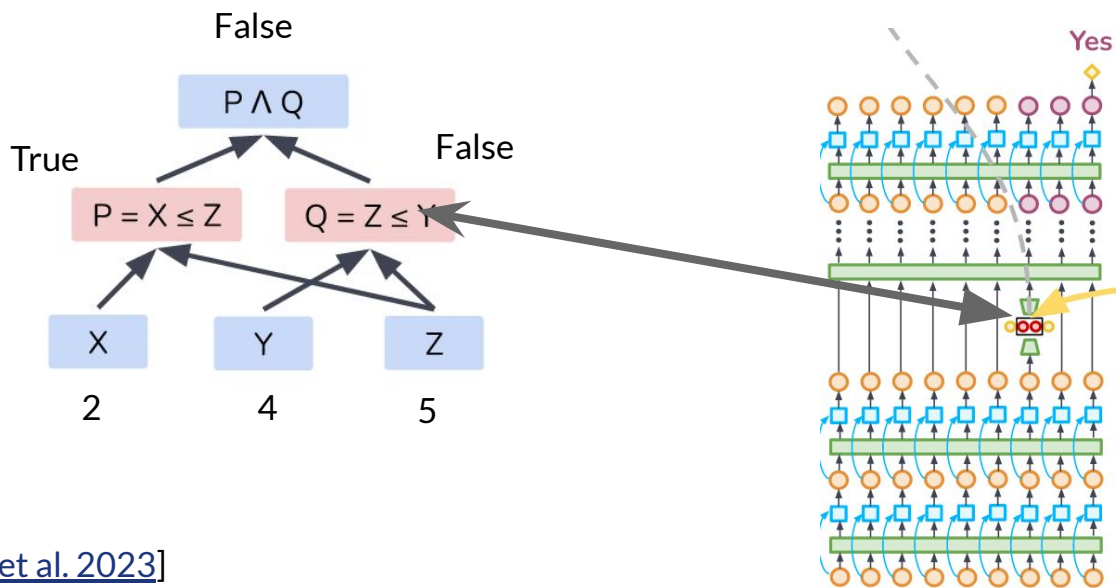

# Intervention analyses is essential to causal abstraction

Key intuition: intervention in the low-level neural representations has the same effect as the intervention in the high-level causal graph.

Coming up with a high-level causal graph is highly non-trivial in practice!

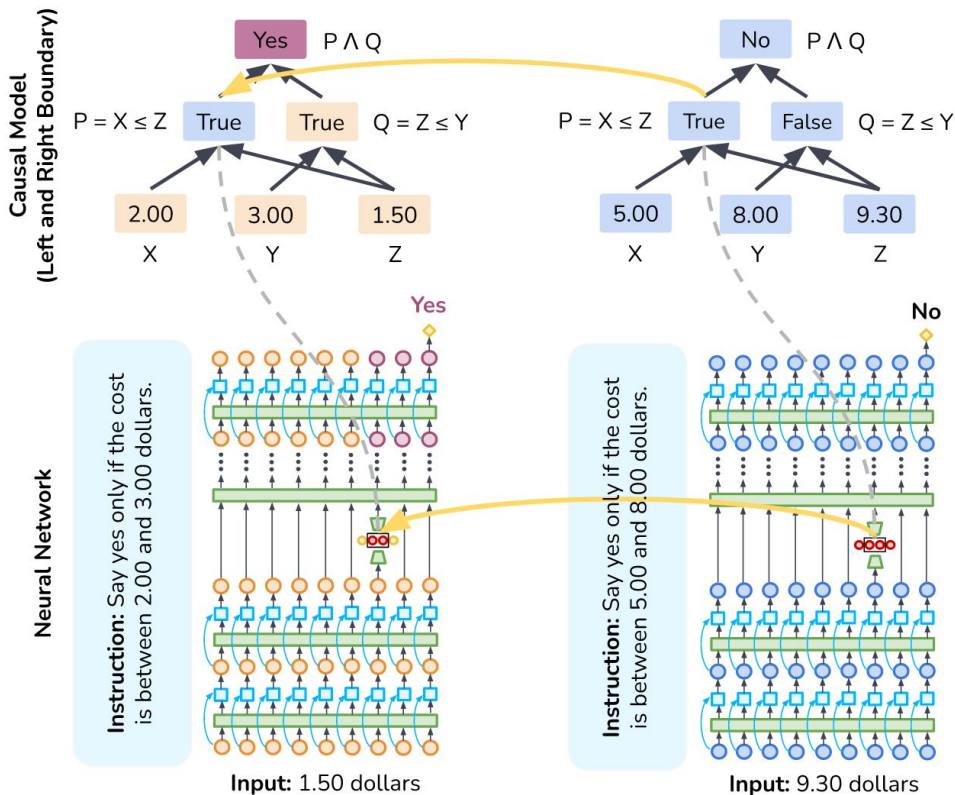

# Causal Probing

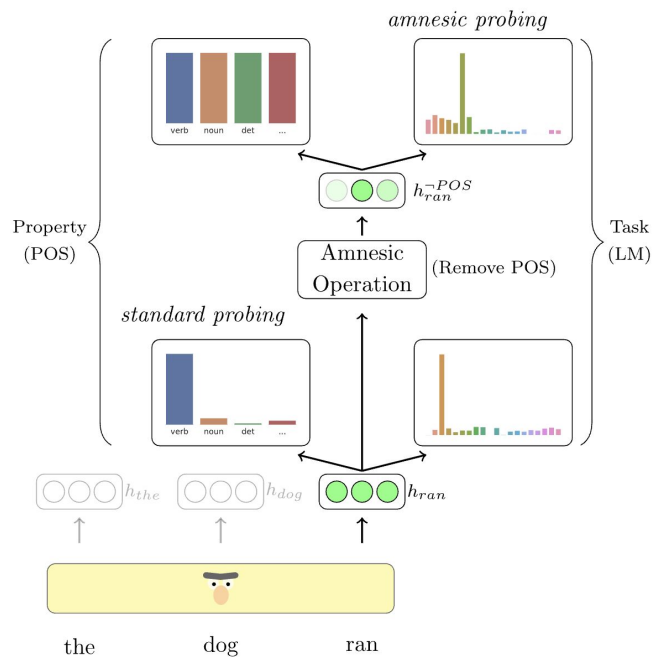

- Traditional probing classifiers are not causal.
- There are methods that perform causal interventions to measure **how** the property of interest is **used** to make predictions.



# Linear Subspace Projections + Concept Erasure

- Models encode many interpretable concepts linearly.

Linear concept subspace hypothesis: a concept (such as gender) lives in low-dimensional **subspace** within the representation space.

**How can we identify the concept subspace?**  
**Once located, can we intervene in its encoding?**

[[Ravfogel et al 2020](#), [Belrose et al 2023](#), inter alia]

Slide credit: [Shauli Ravfogel](#)

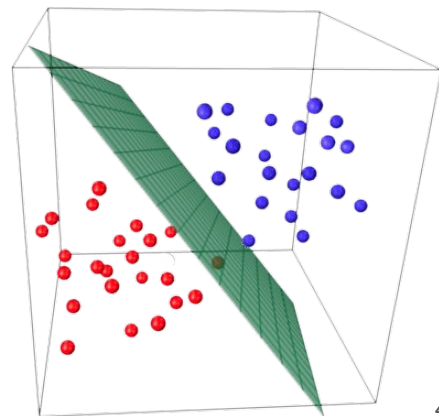

---

# Mechanistic Interpretability

# What is Mechanistic Interpretability?



“reverse engineering the algorithms implemented by neural networks into human-understandable mechanisms, often by examining the weights and activations of neural networks to identify circuits [[Cammara et al., 2020](#), [Elhage et al., 2021](#)] that implement particular behaviors.”

# What is Mechanistic Interpretability?



“reverse engineering the algorithms implemented by neural networks into human-understandable mechanisms, often by examining the weights and activations of neural networks to identify circuits [Cammarata et al., 2020, Elhage et al., 2021] that implement particular behaviors.”

Desirable outcome of *all* interpretability research: human understanding

Focus of *most* interpretability research: understanding *specific* model behaviors

# What is Mechanistic Interpretability?



“reverse engineering the algorithms implemented by neural networks into human-understandable mechanisms, often by examining the weights and activations of neural networks to identify circuits [Cammarata et al., 2020, Elhage et al., 2021] that implement particular behaviors.”

Format of the explanation

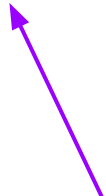

Finding a subset of a network that **traces through the entire network (from starting representation to prediction)**.

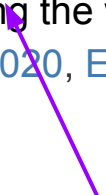

# Circuits

- Note: this has strong resemblances to [sparse sub-network finding](#) in the efficiency literature, but the methods employed to find them differ (also, no retraining of circuits is done)

Transformer circuits localize and characterize transformer LM behavior in a (small) set of components of the model.

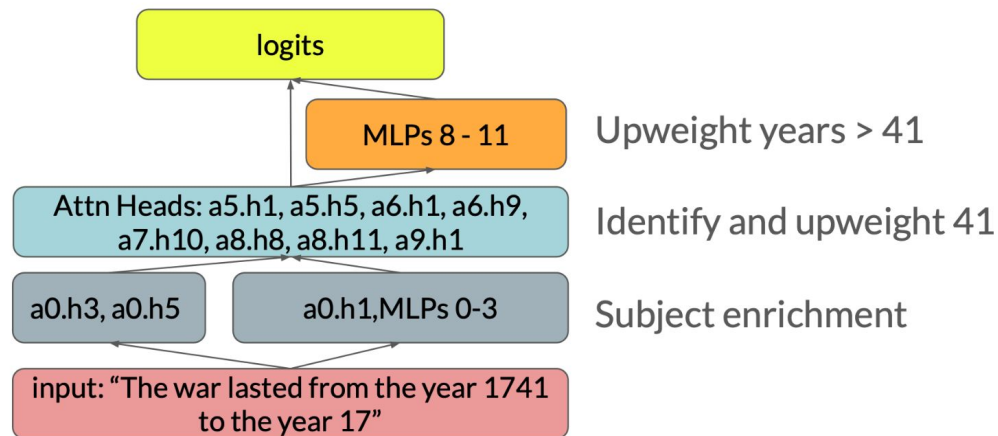

Hanna et al., 2023

# What is mechanistic interpretability?



- It is **inherently causal**.
  - NB! This is **not** how most people use the terminology today.
- It is **not the only** set of causal interpretability methods.
- **Traces through the entire network (from starting representation to prediction).**
- Evaluation:
  - 1) **Faithfulness**: the circuit or subnetwork should be able to *sufficiently replicate the full network* on the behavior of interest
  - 2) **Minimality**: obviously, smaller circuits/subnetworks are better

---

# Methods Leveraging Language Model Strengths

## Linear Structure in Transformers



# Transformer Residual Stream and Linear Structure

- Transformers have a surprising amount of linear structure due to residual connections
- Nonlinearities only occur in two places:
  - Applications of Softmax
    - when computing attention patterns
    - When converting logits to probits at final layer
  - In the MLP functions
- MLP and MHSA functions “read from” and “write to” residual stream to promote/demote certain tokens in output distribution.

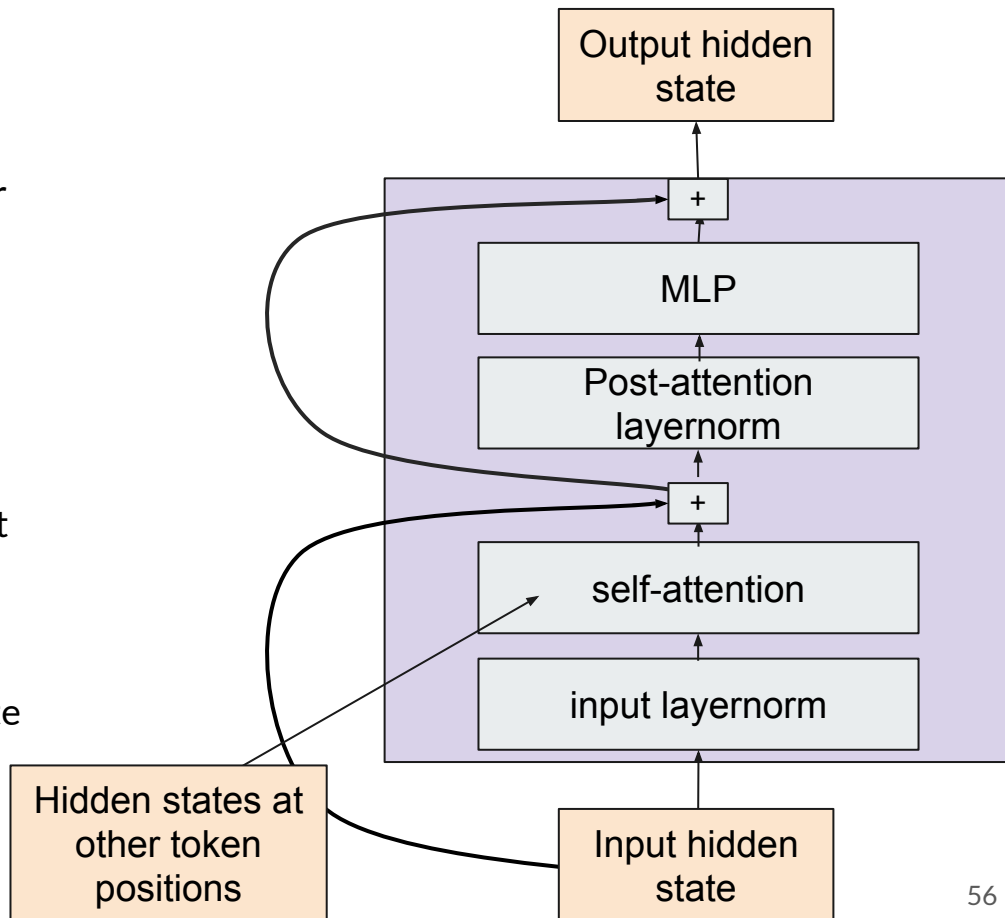

# Transformer Residual Stream and Linear Structure

For input token embedding  $\mathbf{x}_0 \in \mathbb{R}^d$ , the output  $\mathbf{x}_\ell \in \mathbb{R}^d$  of layer  $\ell$  is defined as (for  $\ell \in [1, L]$ ):

$$\mathbf{x}_\ell = \mathbf{x}_{\ell-1} + \text{MHSA}_{\theta_\ell}(\text{LN}(\mathbf{x}_{\ell-1})) + \text{FFN}_{\theta_\ell}(\mathbf{x}_{\ell-1} + \text{MHSA}_{\theta_\ell}(\text{LN}(\mathbf{x}_{\ell-1})))$$

Output of  
previous layer  
= input to  
current layer

Multi-head  
self-attention

Layer norm  
(or some  
other input  
normalization  
scheme)

Feed-forward  
network  
(MLP)

Vector addition  
establishes residual  
connections

# Transformer Residual Stream and Linear Structure

For input token embedding  $\mathbf{x}_0 \in \mathbb{R}^d$ , the output  $\mathbf{x}_\ell \in \mathbb{R}^d$  of layer  $\ell$  is defined as (for  $\ell \in [1, L]$ ):

$$\mathbf{x}_\ell = \mathbf{x}_{\ell-1} + \text{MHSA}_{\theta_\ell}(\text{LN}(\mathbf{x}_{\ell-1})) + \text{FFN}_{\theta_\ell}(\mathbf{x}_{\ell-1} + \text{MHSA}_{\theta_\ell}(\text{LN}(\mathbf{x}_{\ell-1})))$$

Output of  
previous layer  
= input to  
current layer

Multi-head  
self-attention

Layer norm  
(or some  
other input  
normalization  
scheme)

Feed-forward  
network  
(MLP)

Vector addition  
establishes residual  
connections

$$\mathbf{x}_L = \mathbf{x}_0 + \sum_{\ell=0}^{L-1} \left[ \text{MHSA}_{\theta_{\ell+1}}(\text{LN}(\mathbf{x}_\ell)) + \text{FFN}_{\theta_{\ell+1}}(\mathbf{x}_\ell + \text{MHSA}_{\theta_{\ell+1}}(\text{LN}(\mathbf{x}_\ell))) \right]$$

# Transformer Residual Stream and Linear Structure

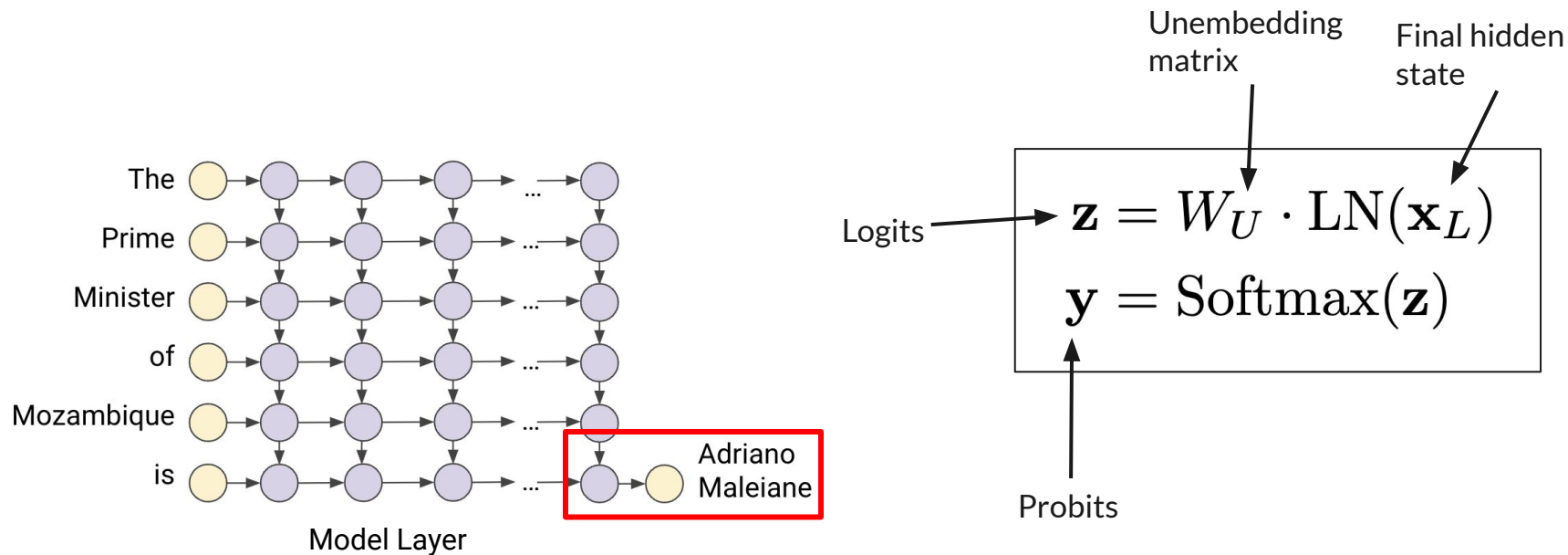

## Implications: Direct Additive Contributions

- Each hidden state output by a {attention head, MHSA function, FFN function, or full Transformer block} has a **direct additive contribution to the final hidden state of the model**
- And, by distributivity of vector addition and vector-matrix multiplication, thus has a **direct additive contribution to the final logits.**

$$\mathbf{x}_L = \mathbf{x}_0 + \sum_{\ell=0}^{L-1} \left[ \text{MHSA}_{\theta_{\ell+1}}(\text{LN}(\mathbf{x}_\ell)) + \text{FFN}_{\theta_{\ell+1}}(\mathbf{x}_\ell + \text{MHSA}_{\theta_{\ell+1}}(\text{LN}(\mathbf{x}_\ell))) \right]$$

$$\mathbf{z} = W_U \cdot \text{LN} \left( \mathbf{x}_0 + \sum_{\ell=0}^{L-1} \left[ \text{MHSA}_{\theta_{\ell+1}}(\text{LN}(\mathbf{x}_\ell)) + \text{MLP}_{\theta_{\ell+1}}(\mathbf{x}_\ell + \text{MHSA}_{\theta_{\ell+1}}(\text{LN}(\mathbf{x}_\ell))) \right] \right)$$

## Direct vs. Indirect Effects

- It's important to note that each hidden state has both a **direct linear** and **indirect nonlinear** contribution to the final hidden state.
- The additive decomposition only applies to **direct** contributions.

$$\mathbf{z} = W_U \cdot \text{LN} \left( \mathbf{x}_0 + \sum_{\ell=0}^{L-1} \left[ \underbrace{\text{MHSA}_{\theta_{\ell+1}}(\text{LN}(\mathbf{x}_\ell))}_{\text{direct}} + \text{MLP}_{\theta_{\ell+1}} \left( \mathbf{x}_\ell + \underbrace{\text{MHSA}_{\theta_{\ell+1}}(\text{LN}(\mathbf{x}_\ell))}_{\text{indirect}} \right) \right] \right)$$

This MHSA function has a direct additive contribution to the logits via this term

But it also has an indirect, nonlinear contribution as input to the MLP function

---

# Methods Leveraging Language Model Strengths

## Vocabulary Projection

# Vocabulary Projection on Transformer Hidden States

- Propose to project each hidden state to the space of probabilities over vocab tokens using the unembedding matrix

$$\mathbf{y} = \text{Softmax}(W_U \cdot \text{LN}(\mathbf{x}_L))$$

Final hidden state -  
replace with any  
d-dimensional  
hidden state from  
the network.

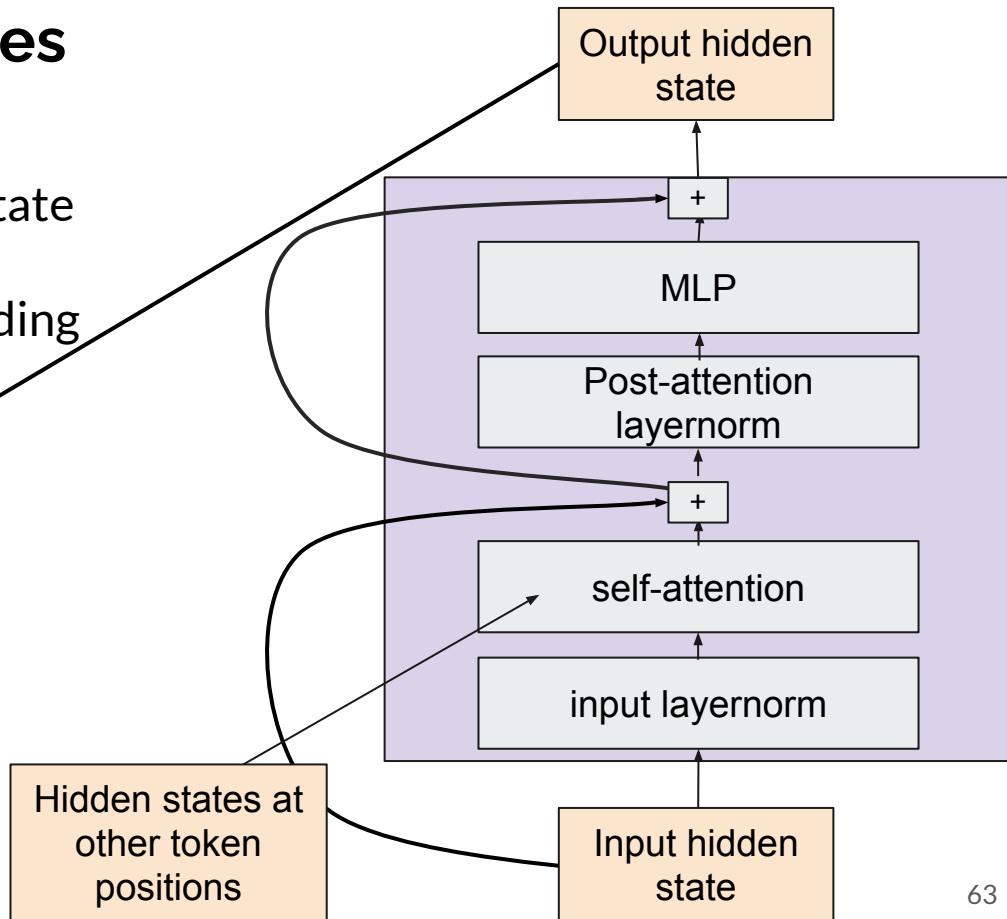



# Vocabulary Projection on Transformer Hidden States

		Concept	Sub-update top-scoring tokens
GPT2	$\mathbf{v}_{1018}^3$	Measurement semantic	kg, percent, spread, total, yards, pounds, hours
	$\mathbf{v}_{1900}^8$	WH-relativizers syntactic	which, whose, Which, whom, where, who, wherein
	$\mathbf{v}_{2601}^{11}$	Food and drinks semantic	drinks, coffee, tea, soda, burgers, bar, sushi
WIKILM	$\mathbf{v}_1^1$	Pronouns syntactic	Her, She, Their, her, she, They, their, they, His
	$\mathbf{v}_{3025}^6$	Adverbs syntactic	largely, rapidly, effectively, previously, normally
	$\mathbf{v}_{3516}^{13}$	Groups of people semantic	policymakers, geneticists, ancestries, Ohioans

Table 1: Example value vectors in GPT2 and WIKILM promoting human-interpretable concepts.

# Vocabulary Projection on Transformer Hidden States

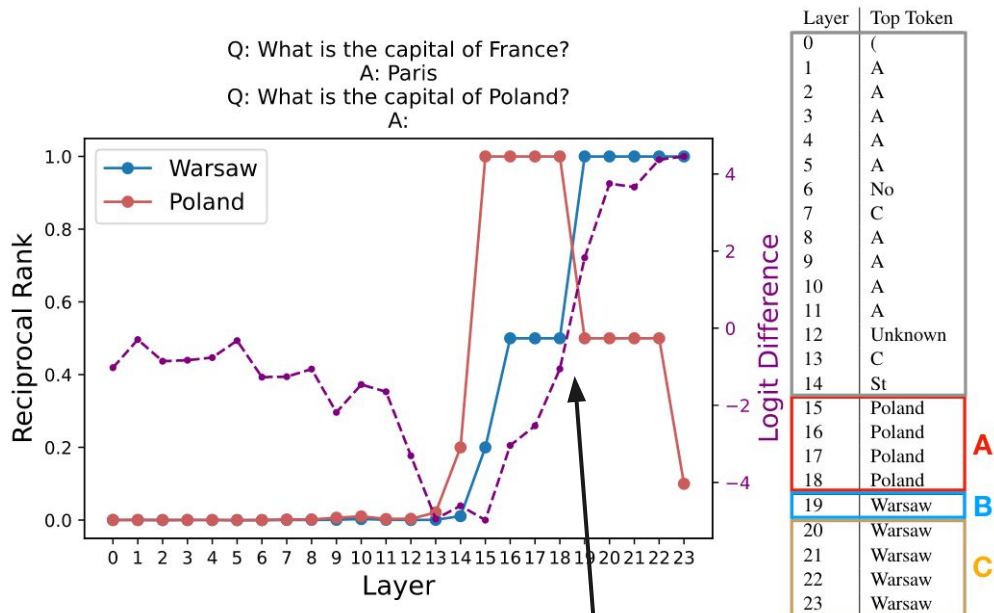

Validated with causal intervention:

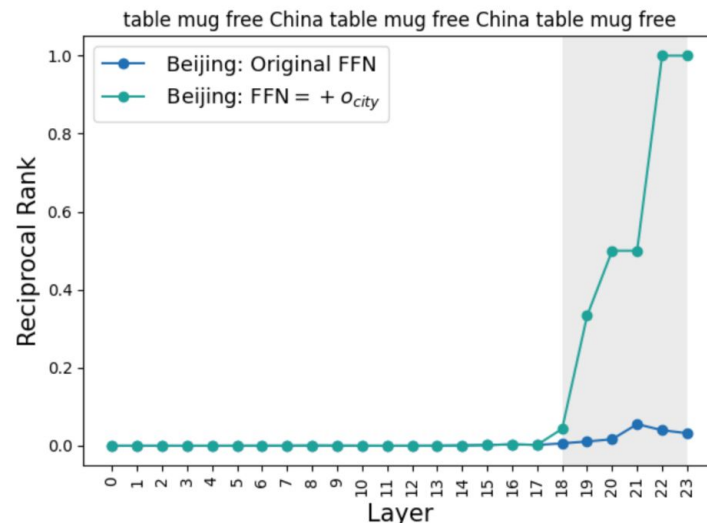

# Patchscopes

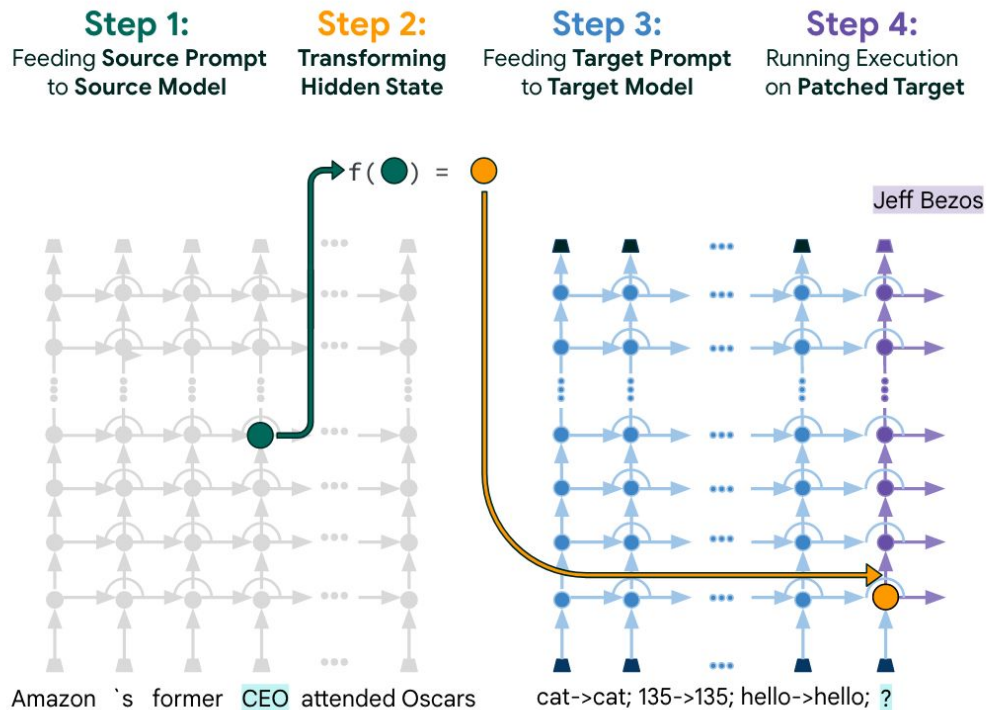

# Learning Linear Transformation Matrices

- Propose to project each hidden state to the space of probabilities over vocab tokens using ~~the unembedding matrix~~ a learned weight matrix for each layer

$$y = \text{Softmax}(W_U \cdot \text{LN}(x_L))$$

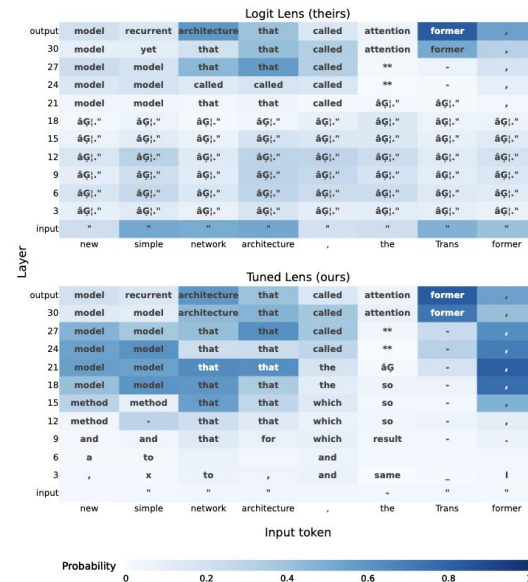

Figure 1. Comparison of our method, the *tuned lens* (bottom), with the “logit lens” (top) for GPT-Neo-2.7B prompted with an excerpt from the abstract of [Vaswani et al. \(2017\)](#). Each cell shows the top-1 token predicted by the model at the given layer and token index. The logit lens fails to elicit interpretable predictions before layer 21, but our method succeeds.

# Notes



- Can be thought of as “early exiting” the Transformer block at inference time
- From a causal perspective:
  - (Attempts to) measure *direct* effects
    - How faithful this is depends on the exact application of normalization
    - It is not a causal mediation
- Can’t uncover ways in which hidden states are promoting tokens in other linear (or non-linearly decodable) subspaces
  - I.e., negative results are uninformative
  - Mostly only useful at later layers
- Top-k tokens being coherent: does this just mean that the unembedding matrix is well-formed?

---

# Methods Leveraging Language Model Strengths

Decoding Natural Language  
Explanations from Representations

# Focus of This Part



Decoding **natural Language explanations** from neurons

(using LLMs)

Prominent paradigm of using LLMs for automating the process of explaining neurons

- Step1: Propose hypothesis explanations
- Step2: Verify explanations

# Using GPT-4 to Explain Neurons of GPT-2



May 9, 2023

Language models can explain  
neurons in language models

[Read paper ↗](#)

[View neurons ↗](#)

[View code and dataset ↗](#)



# Using GPT-4 to Explain Neurons of GPT-2

## Activations of a neuron in

GPT-2

a very special event in collaboration with ArenaNet to give away 20 Scarlet Briar t-shirts. Oh, and they're quite lovely. Scarlet Briar began her reign of terror months ago, launching assault after **assault** upon Tyria and its people. Together with the Aetherblade pirates, she unleashed world bosses and catastrophic inv

just so. But do you think they call me Roberts the Cathedral Builder? No."He points out the other window. "You see that pier on the lake out there? I built that pier with my bare hands, driving the pilings 10-feet into the sand, laying the pier plank by **plank** but

. Once inside Himkok, you are greeted by an interior that is an even cross between a Prohibition hideout and modern laboratory. Featuring prominently to your eyes upon entry will be jar after **jar** of pickled fruits and vegetables, which is an homage to the days of Prohibition when secret bars would set up elaborate fronts of legitimate

Health Statistics and based on a sample of 58,488 women and 24,652 men in the United States. To reach his findings, he then ran projections for the Millennial Generation as they age, comparing people who were born between 1940 and 1990 decade-by-decade. **ade**."To me the most surprising

Explanation: X by / after X

# Using GPT-4 to Explain Neurons of GPT-2

Propose hypothesis: few-shot prompting

## Step 1 Explain the neuron's activations using GPT-4

Show neuron activations to GPT-4:

The Avengers to the big screen, Joss Whedon has returned to reunite Marvel's gang of superheroes for their toughest challenge yet. Avengers: Age of Ultron pits the titular heroes against a sentient artificial intelligence, and smart money says that it could soar at the box office to be the highest-grossing film of the

introduction into the Marvel cinematic universe, it's possible, though Marvel Studios boss Kevin Feige told Entertainment Weekly that, "Tony is earthbound and facing earthbound villains. You will not find magic power rings firing ice and flame beams." Spoilsport! But he does hint that they have some use... STARK T

, which means this Nightwing movie is probably not about the guy who used to own that suit. So, unless new director Matt Reeves' The Batman is going to dig into some of this backstory or introduce the Dick Grayson character in his movie, the Nightwing movie is going to have a lot of work to do explaining

of Avengers who weren't in the movie and also Thor try to fight the infinitely powerful Magic Space Fire Bird. It ends up being completely pointless, an embarrassing loss, and I'm pretty sure Thor accidentally destroys a planet. That's right. In an effort to save Earth, one of the heroes inadvertently blows up an

GPT-4 gives an explanation, guessing that the neuron is activating on

references to movies, characters, and entertainment.

# Using GPT-4 to Explain Neurons of GPT-2

Propose hypothesis: few-shot prompting

Few-Shot Activation-Explanation Pairs + Input Activations



Explanations

```
<start>
  together      3
  ness          7
  town          1
<end>
<start>
[prompt truncated ...]
<end>
```

```
Explanation of neuron 1 behavior: the main thing this neuron does is find phrases related to
community
```

# Using GPT-4 to Explain Neurons of GPT-2

Verify hypothesis:

simulate activations based on explanations; compare simulated and actual activations

## Activations Obtained by GPT-4

Assuming that the neuron activates on

references to movies, characters, and entertainment.

GPT-4 guesses how strongly the neuron responds at each token:

: Age of **Ultron** and it sounds like his role is going to play a bigger part in the **Marvel** cinematic universe than some of you originally thought. **Marvel** has a new press release that offers up some information on the characters in the film. Everything included in it is pretty standard stuff, but then there was this new

their upcoming 13-episode series for **Marvel's Daredevil**. It begins with a young **Matt Murdock** telling his blind martial arts master **Stick** that he lost his sight when he was 9-years-old. And then me into the present with a grateful **Karen Page** explaining that a masked vigilante saved her life.

offbeat , Screenshots | Follow This Author @KartikMdgl We have two images from **Skyrim**, which totally stumped us. They show a walking barrel, and we're not sure how exactly that happened. Check out these two images below. Some people really do some weird

ultimate in lightweight portability. Generating chest-thumping lows and crystal clear highs, the four models in the series – the XLS1000, XLS1500, XLS2000, and XLS2500 – are engineered to meet any demanding audio requirements – reliably and within budget. Every XLS

## Actual Activations

: Age of **Ultron** and it sounds like his role is going to play a bigger part in the **Marvel** cinematic universe than some of you originally thought. **Marvel** has a new press release that offers up some information on the characters in the film. Everything included in it is pretty standard stuff, but then there was this new

their upcoming 13-episode series for **Marvel's Daredevil**. It begins with a young **Matt Murdock** telling his blind martial arts master **Stick** that he lost his sight when he was 9-years-old. And then me into the present with a grateful **Karen Page** explaining that a masked vigilante saved her life.

offbeat , Screenshots | Follow This Author @KartikMdgl We have two images from **Skyrim**, which totally stumped us. They show a walking barrel, and we're not sure how exactly that happened. Check out these two images below. Some people really do some weird

ultimate in lightweight portability. Generating chest-thumping lows and crystal clear highs, the four models in the series – the XLS1000, XLS1500, XLS2000, and XLS2500 – are engineered to meet any demanding audio requirements – reliably and within budget. Every XLS

compare



# Evaluating the NL Explanations of Neurons

Whether explanations accurately align with neuron activations?

- Type-1 Error (recall): falsely predicts that the neuron will activate on a concept
- Type-2 Error (precision): falsely predicts that the neuron will not activate on a concept

Explanation	True Positives	Type I Errors	Type II Errors
days of the week	I have a music class every <b>Wednesday</b> evening	Thursday <b>is</b> usually reserved for grocery	Philadelphia <b>is</b> where the Declaration of Independence
years, specifically four-digit years	<b>Castro</b> took power in Cuba in <b>1959</b> .	rated during re - entry in <b>2003</b> .	We need to <b>rev</b> amp the website to attract more

**Not** well aligned: Around 0.6 F1 score across 300 of the top-scoring explanations found by GPT-4

# Takeaways



LLMs can help annotate/summarize concepts from collections of text snippets

But LLM-produced neuron-level explanations are not accurate enough

---

# Recap

# Recap: Looking into transformers



- Pros
  - We are actually studying the weights in the model. Intuitively, it is more likely to be faithful.
  - Many methods are extensible to other types of models, modalities, etc.
- Cons
  - High-dimensional spaces remain challenging to make sense of and there could existing fundamental limitations so that it is impossible to reverse-engineer the model or for humans to make sense of these models
  - Illusion of understanding
  - Negative results can be uninformative
  - Lack of standardized evaluation & benchmarks
- Open questions
  - What granularity or type of model internals to target?
  - How to unify work from various methods/communities?